

Prado

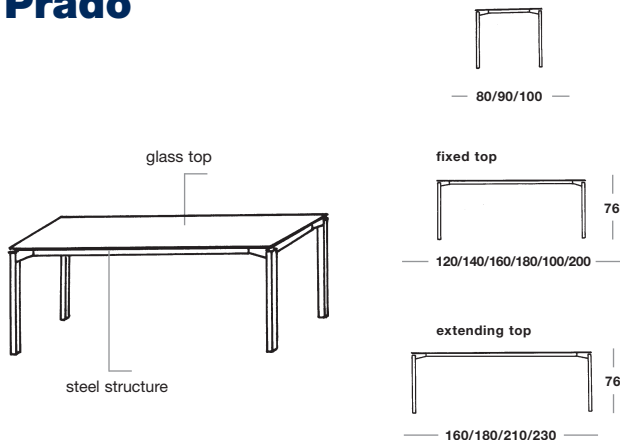

Fixed top

L 120 P 80 H 76
 L 140 P 80 H 76
 L 160 P 90 H 76
 L 180 P 90 H 76
 L 100 P 100 H 76
 L 200 P 100 H 76

Extending top

L 120/157 P 80 H 76
 L 140/180 P 80 H 76
 L 160/210 P 90 H 76
 L 180/230 P 90 H 76

Product sheet

Element	Material
Structure	Steel tube in chrome plated or non-toxic oven-baked painted steel. Fixed version: anodised aluminium crossbars. Extending version: anodised aluminium telescopic runners.
Top	10mm tempered glass.
Extension	10mm layered solid core. Runners system for extension is in anodised aluminium. Option of inserting one or two extensions.
Characteristics	It is provided with springs which help sliding when extending the table.

Instructions for use

Use and maintenance

This product is suitable for home use; do not hang from it and do not climb on the top. Avoid all kind of impacts to the glass parts; do not carry out any maintenance or repair operations to the product.

Care of the steel and solid core parts

Cleaning must be carried out with neutral detergents which must be dried off immediately. Always use a soft cloth to avoid scratching the surfaces.

Care of the glass parts

Cleaning may be carried out with specific products or with water which must be dried off immediately with a soft cloth. Cleaning must be carried out with great care to avoid scratching the surfaces.